



05A – TECHNISCHE MERKMALE

1. TECHNISCHE DATEN

Igo 21

FEM / 1 – A3

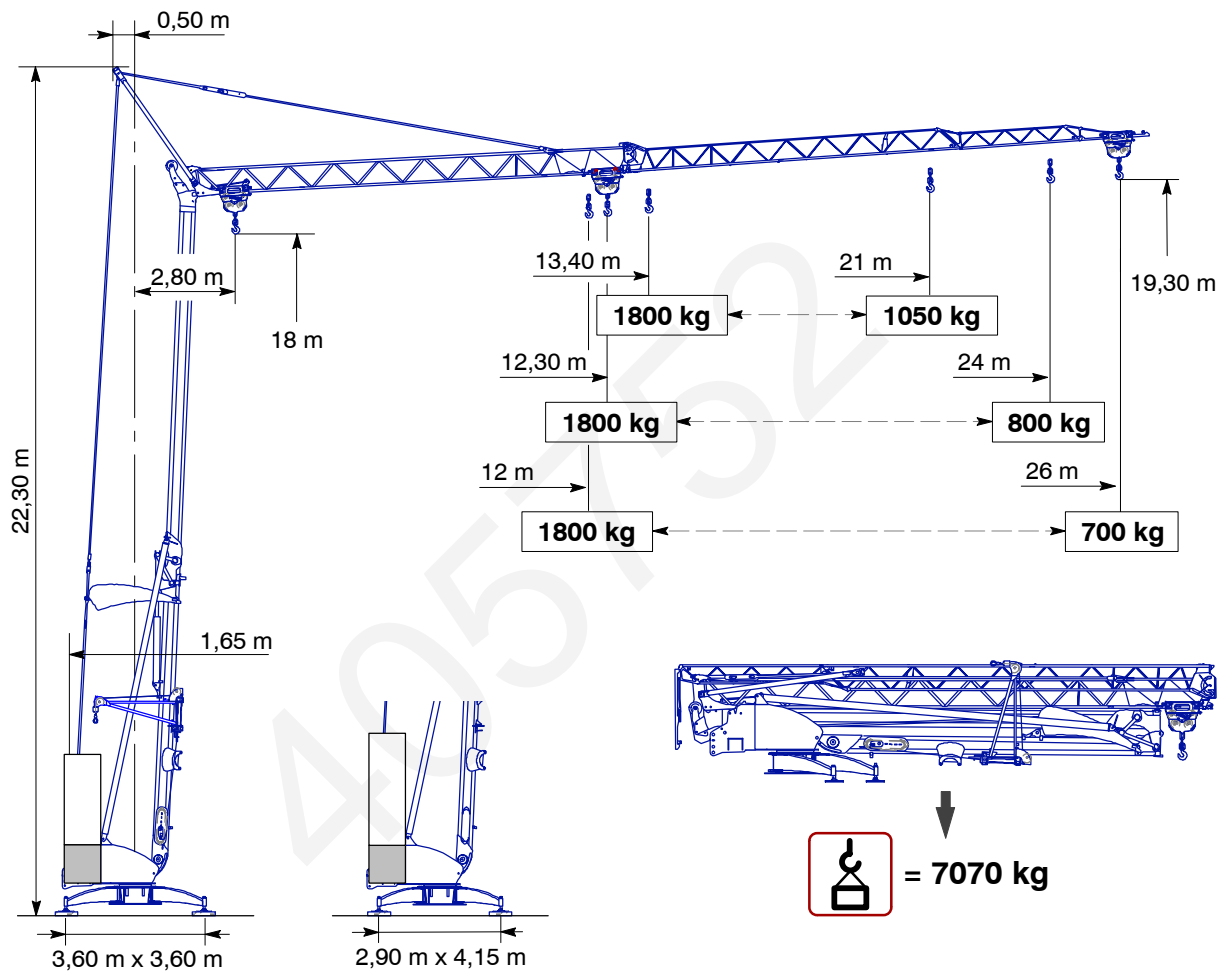



2. LASTKURVEN

Horizontalausleger

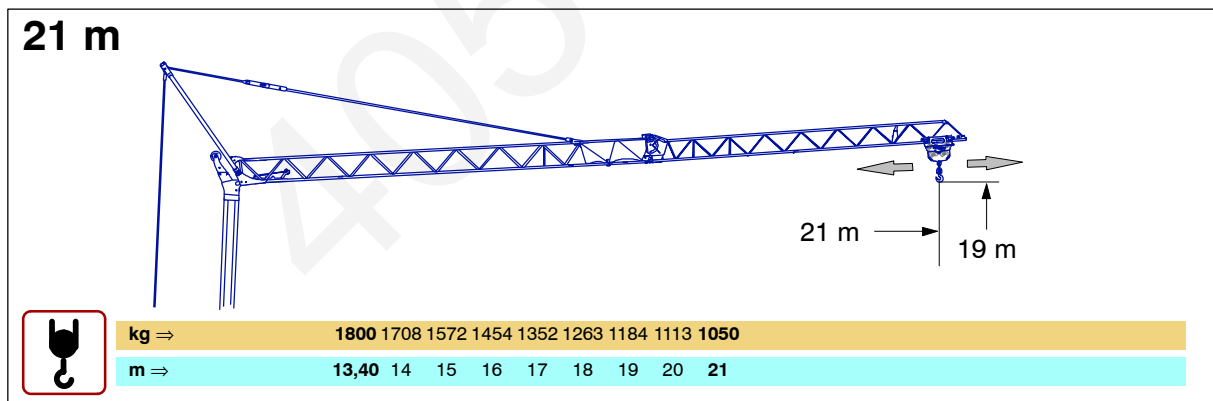
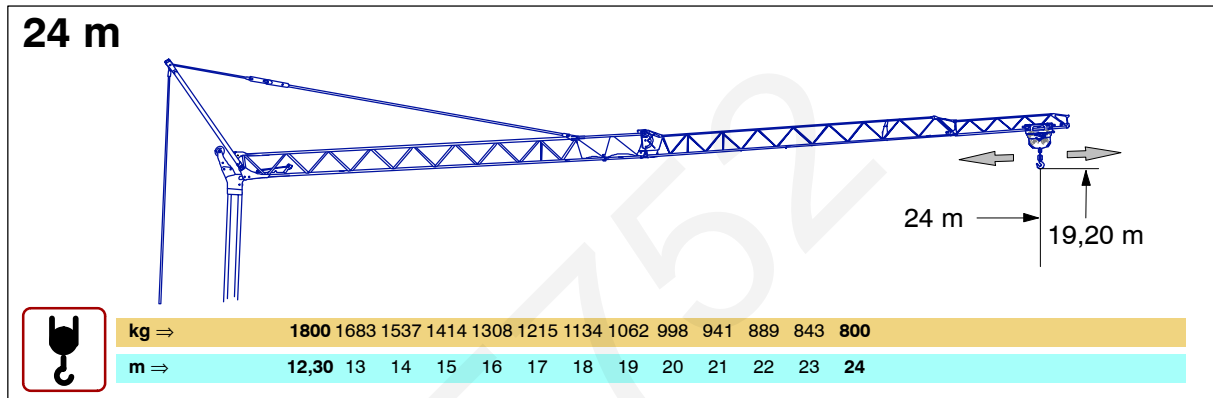
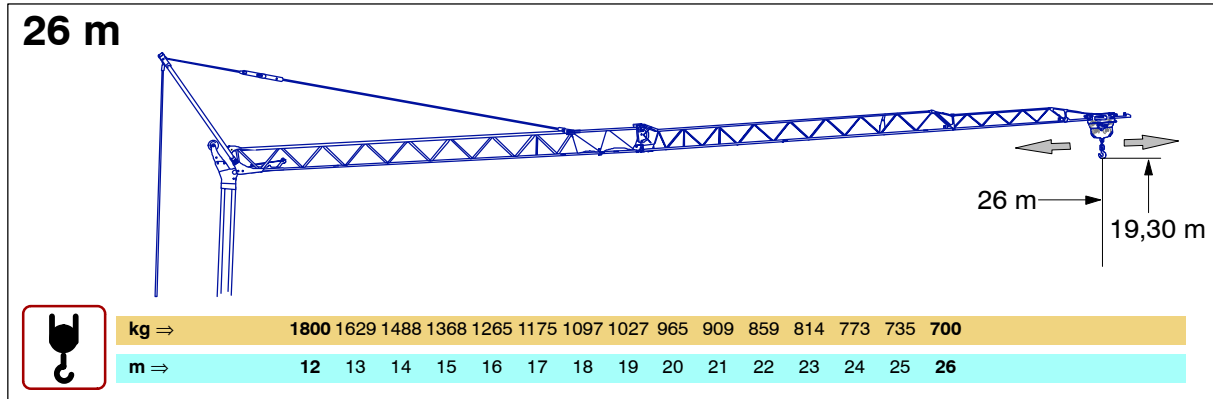

Umgeklappter Horizontalausleger

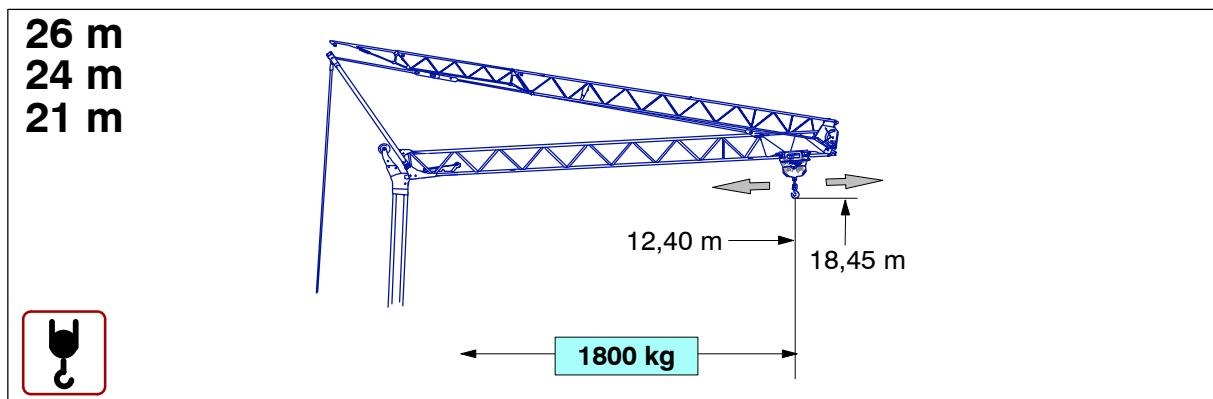



Eingeklappter ausleger mit 20°

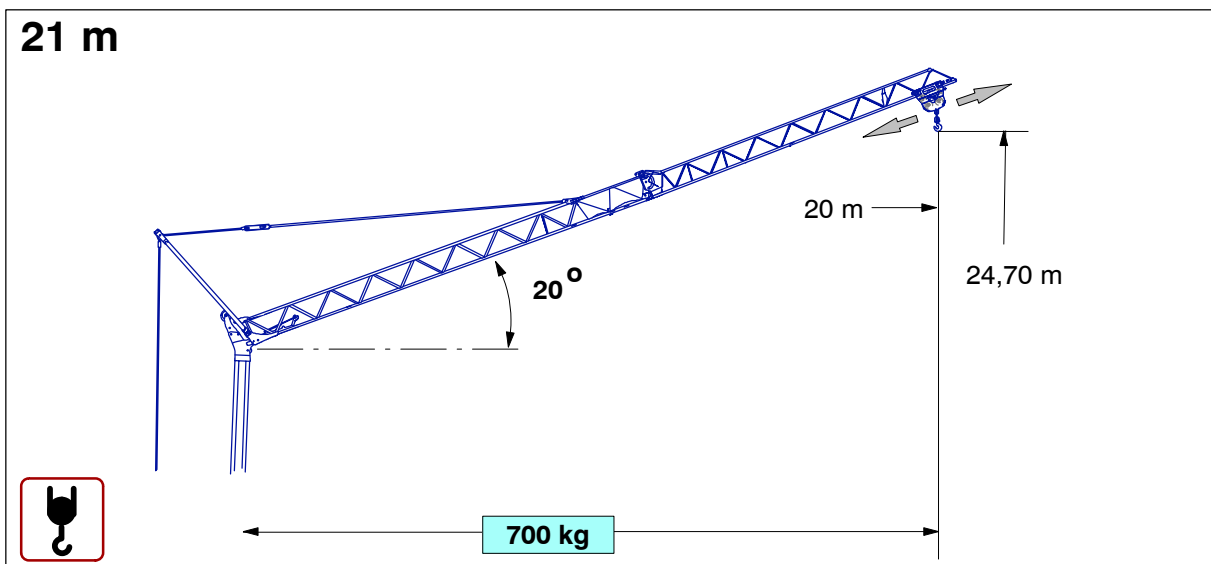
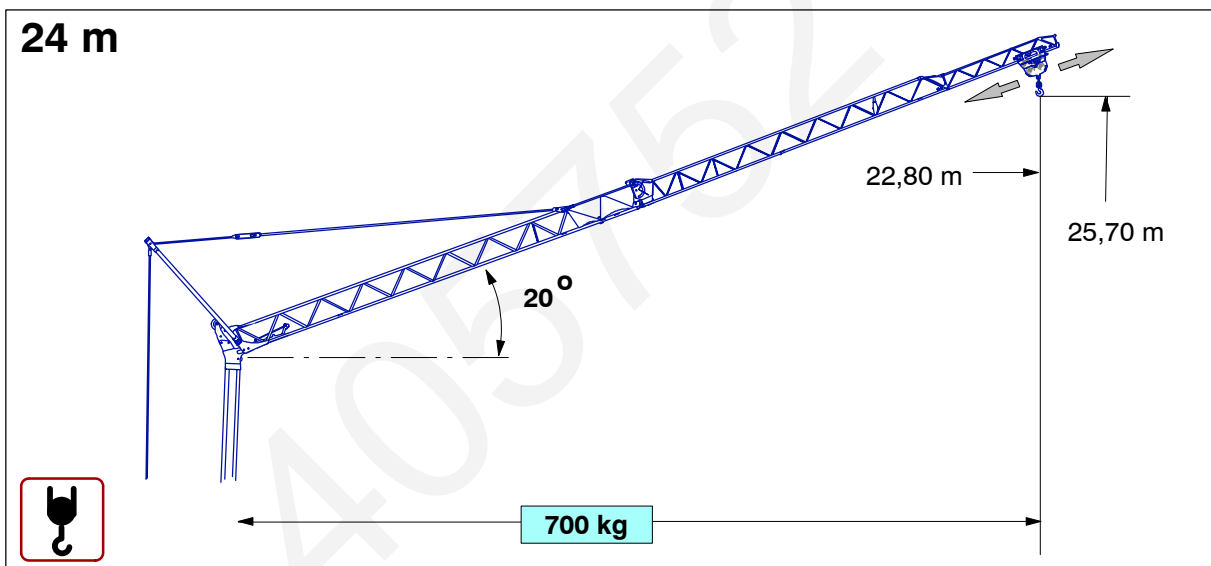
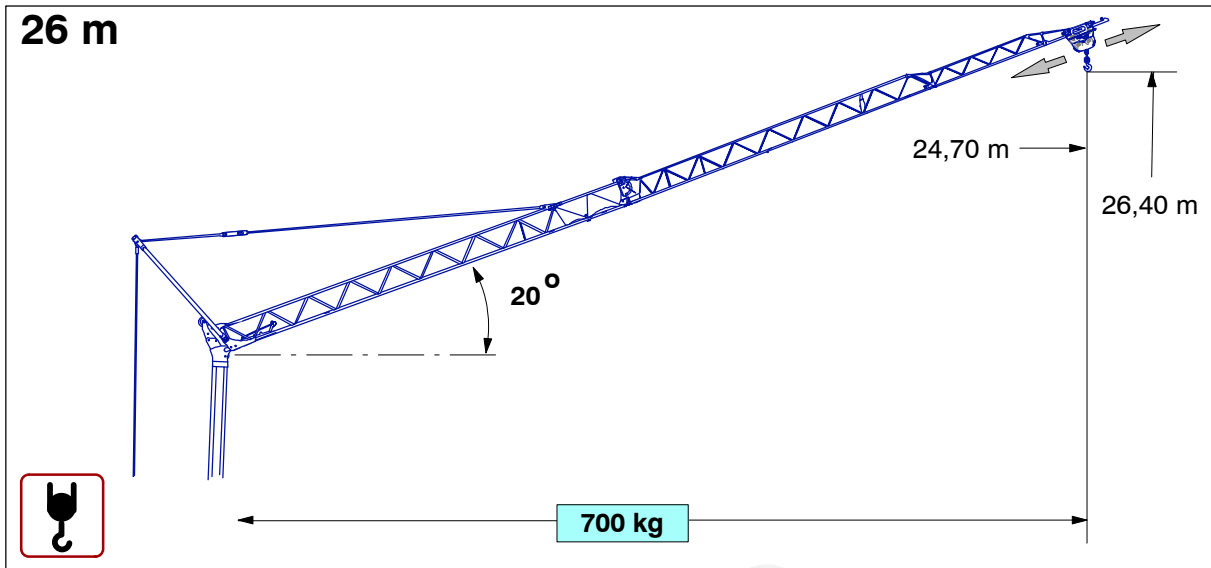



06A – BALLAST

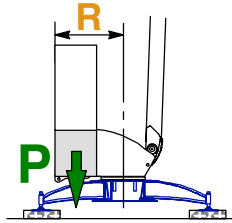

			R (m)	P (kg)	
				IN BETRIEB	AUßER BETRIEB
				 < 72 km/h	 < 150 km/h
	26m	3,60x3,60	2,10	12 120	12 120
			24m	2,00	12 120
	21m	2,90x4,15	1,95	12 470	12 470
			2,10	13 920	13 920
	26m	3,60x3,60	2,00	12 470	12 470
			2,10	14 340	14 340
21m	2,90x4,15	1,95	12 120	12 120	
		2,00	13 920	13 920	
	26m	3,60x3,60	2,10	12 120	
			24m	2,00	
	21m	2,90x4,15	1,95	12 470	
			2,10	13 920	
	26m	3,60x3,60	1,95	14 340	
			2,00	12 120	
21m	2,90x4,15	2,10	12 470		
		1,95	13 920		